

IMMORTALE

a collection by

ANDREA BRANZI

handcrafted by

F.lli ARGIOLAS

for PRETZIADA





Immortale n. 7

## Table of Contents

Introduction	4/5
Text by Andrea Branzi	6/7
Immortale Collection	8 → 39
Curatorial Text	40 → 43
F.lli Argiolas	44/45

IMMORTALE is a collaboration with Andrea Branzi, the pragmatic visionary of Italian design, and Fratelli Argiolas, a family-run blacksmithing workshop from the capital city of Sardinia: Cagliari. The resulting collection is an assortment of fifteen unique sculptures: precious, meticulously hand-crafted black metal boxes representing an unknown destination, and the vitality and silence that dwell within it.





“A family of sculptures, constructed of smooth black iron sheets, free from all rust and from which splinters of fossils emerge, bringing with them proof of ancient lichens and stones.

Today they are silent and deaf, belonging to a deadened universe. And still they express a primordial, almost sacred, vigor.

Completely arid, resistant, inexpressive, heavy as ancient tombs...

Like everything else that, at the outset, appears pointless, they are destined to find their place in the long eternal moments that live outside of daily life, outside of history and of prehistory.”

- Andrea Branzi, Autumn 2020



Andrea Branzi in his studio, photographed by Delfino Sisto Legnani







n. 1

Weight: 1,44 kg

Materials: Hand-welded, painted iron;  
Fossilized shale; Gold foil

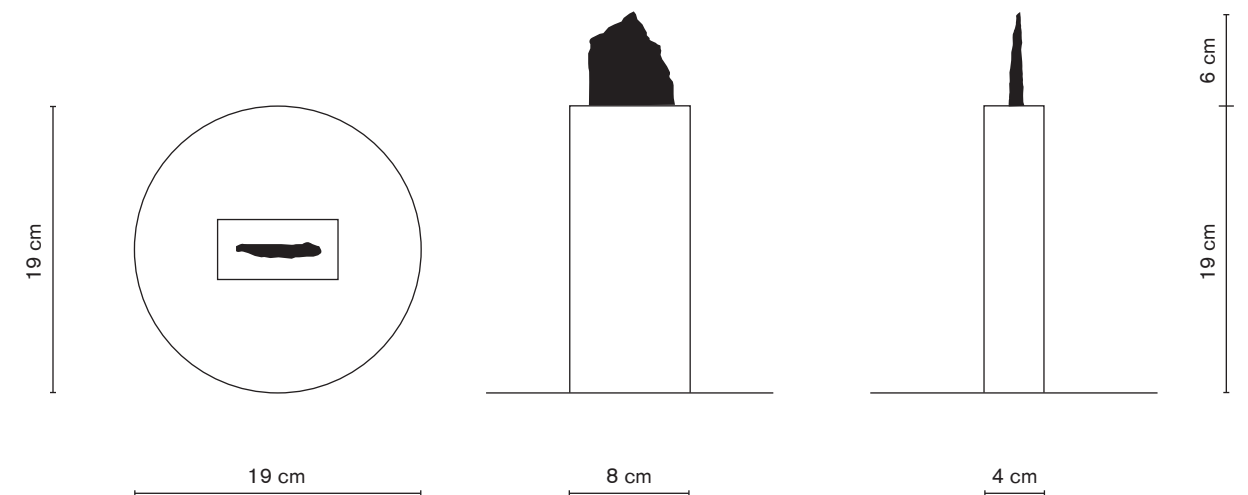



n. 2

Weight: 10,8 kg

Materials: Hand-welded, painted iron and cast iron foot

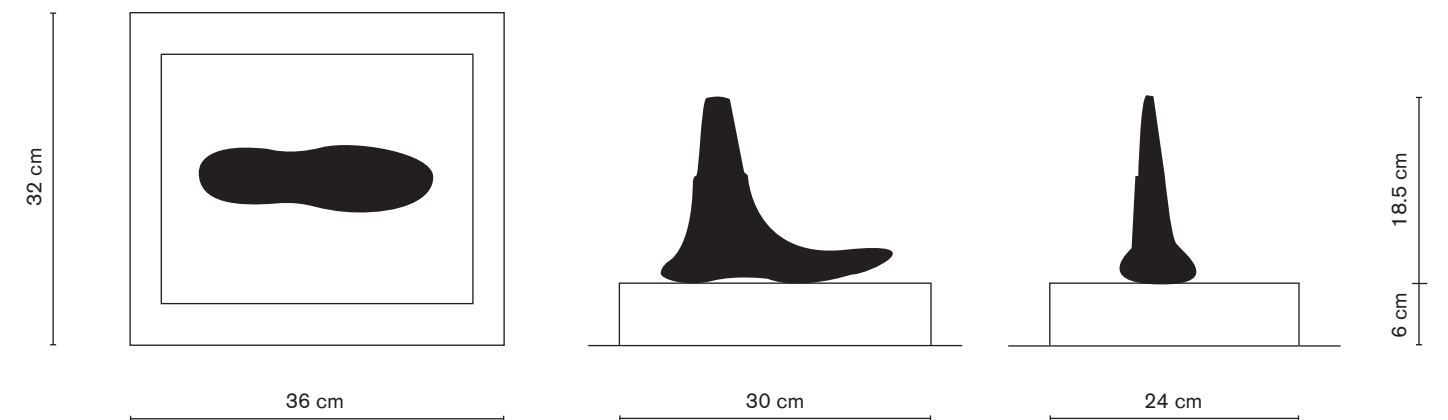





n. 3

Weight: 4,35 kg

Materials: Hand-welded, painted iron;  
Fossilized shale; Granite stone

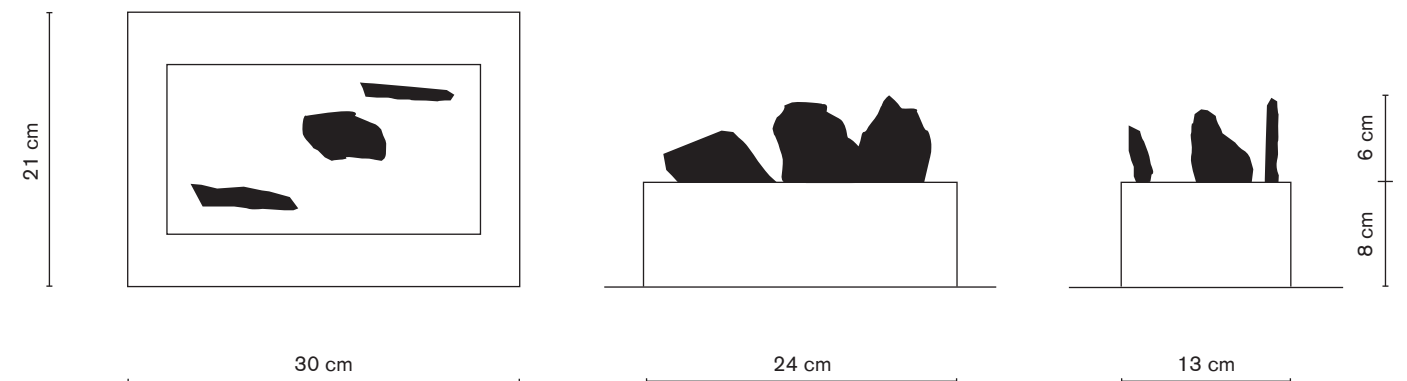



n. 4

Weight: 0,65 kg

Materials: Hand-welded, painted iron;  
Fossilized shale; Gold foil

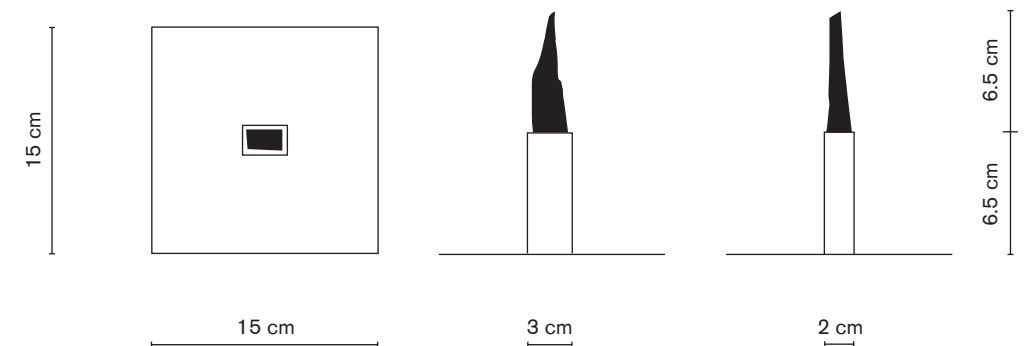

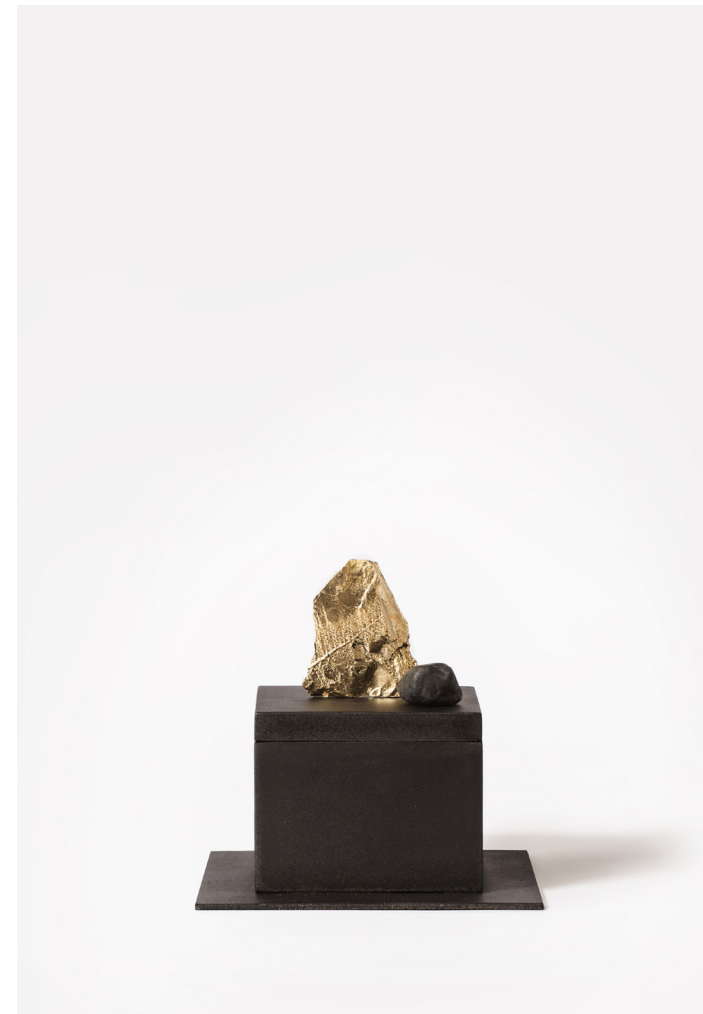

n. 5

Weight: 2,54 kg

Materials: Hand-welded, painted iron;  
Fossilized shale; Gold foil;  
Basalt river stone

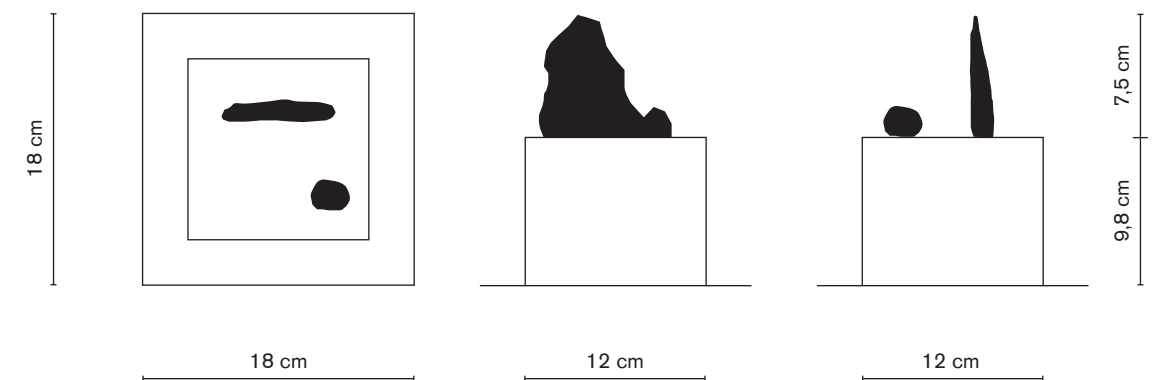





n. 6

Weight: 3,6 kg

Materials: Hand-welded, painted iron;  
Fossilized shale

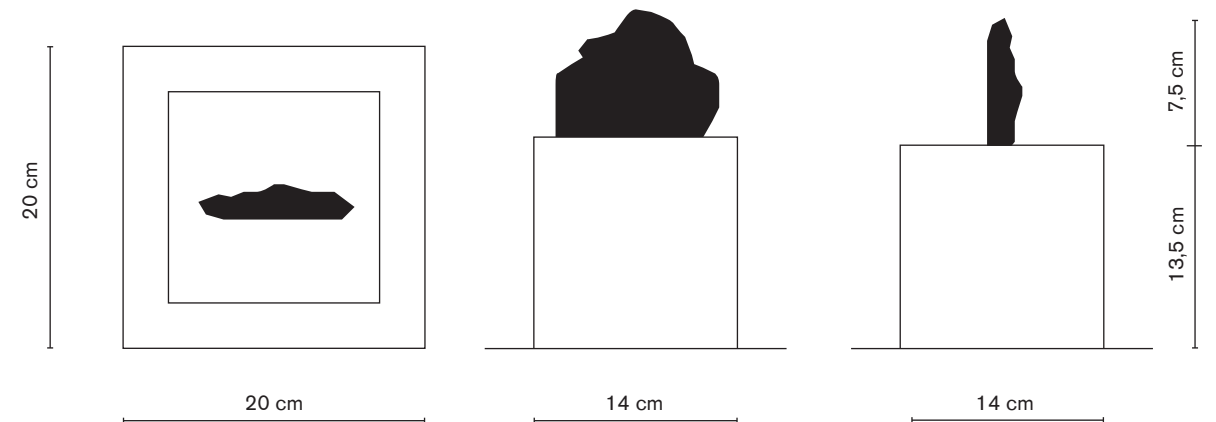



n. 7

Weight: 5,8 kg

Materials: Hand-welded, painted iron;  
Fossilized shale

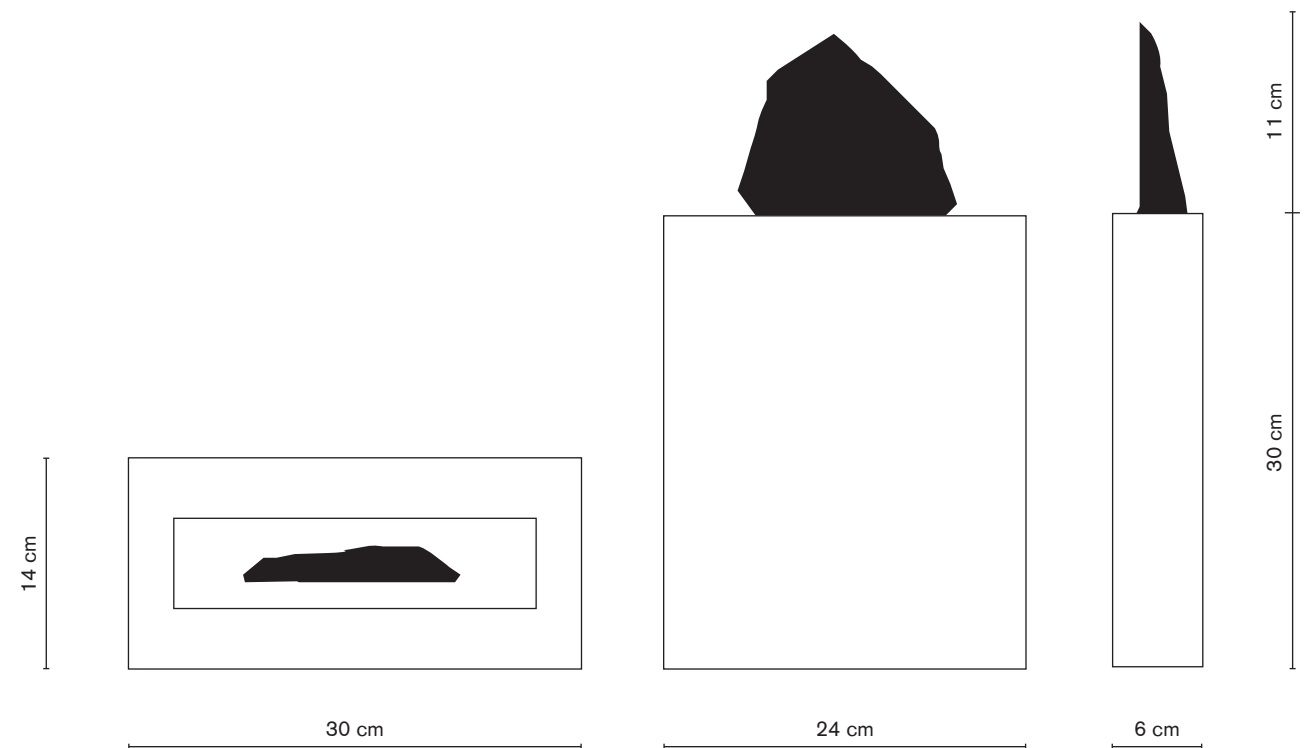

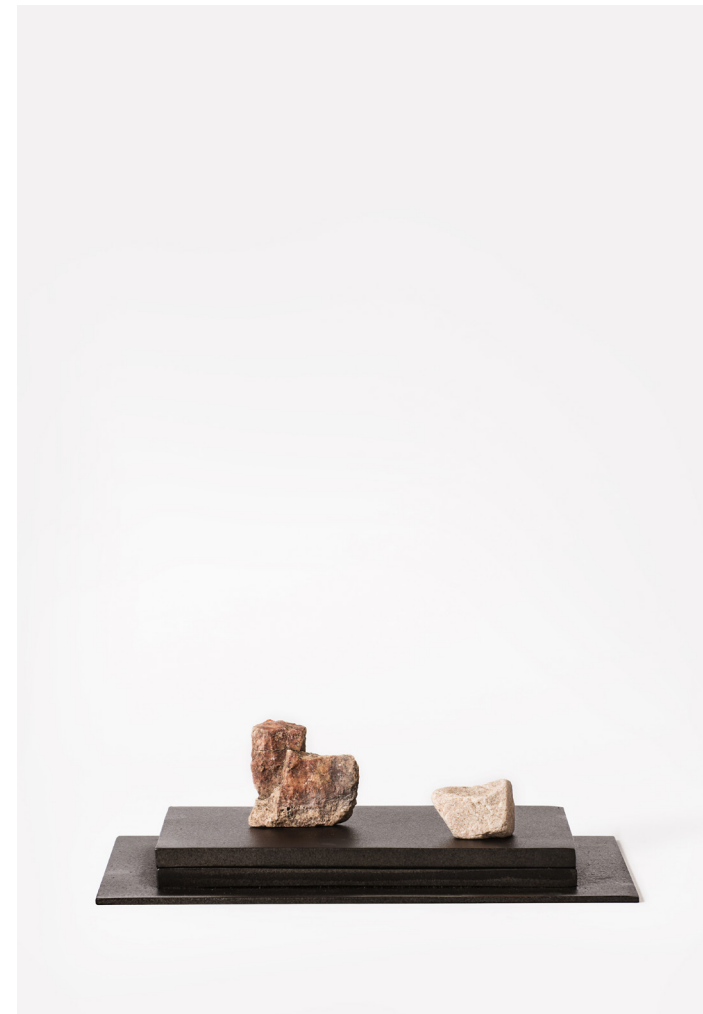

n. 8

Weight: 3,2 kg

Materials: Hand-welded, painted iron;  
Feldspar; Trachyte

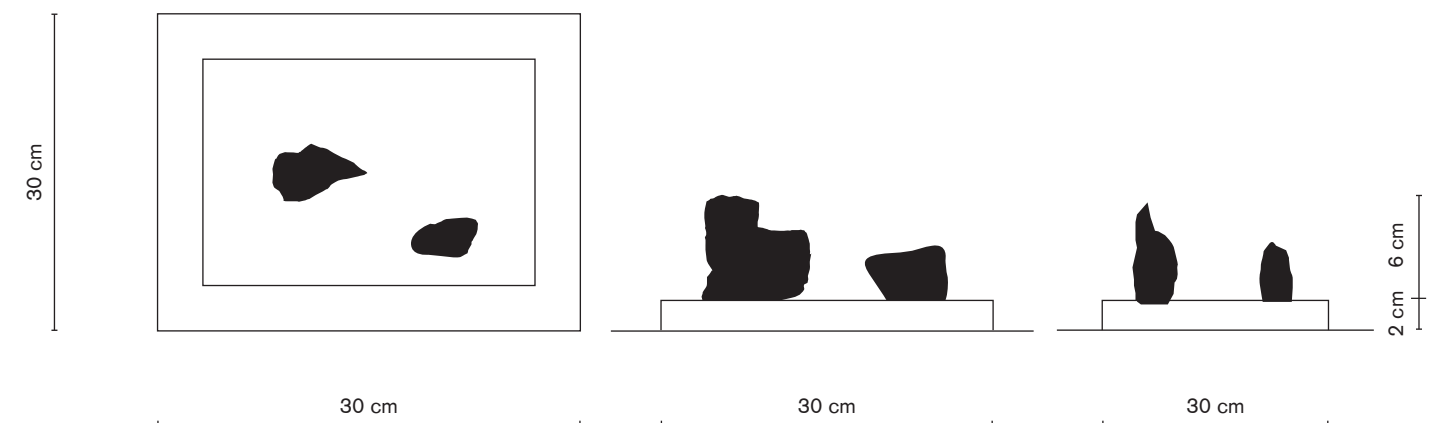





n. 9

Weight: 7,5 kg

Materials: Hand-welded, painted iron;  
Fossilized shale; Gold foil;  
Andesite

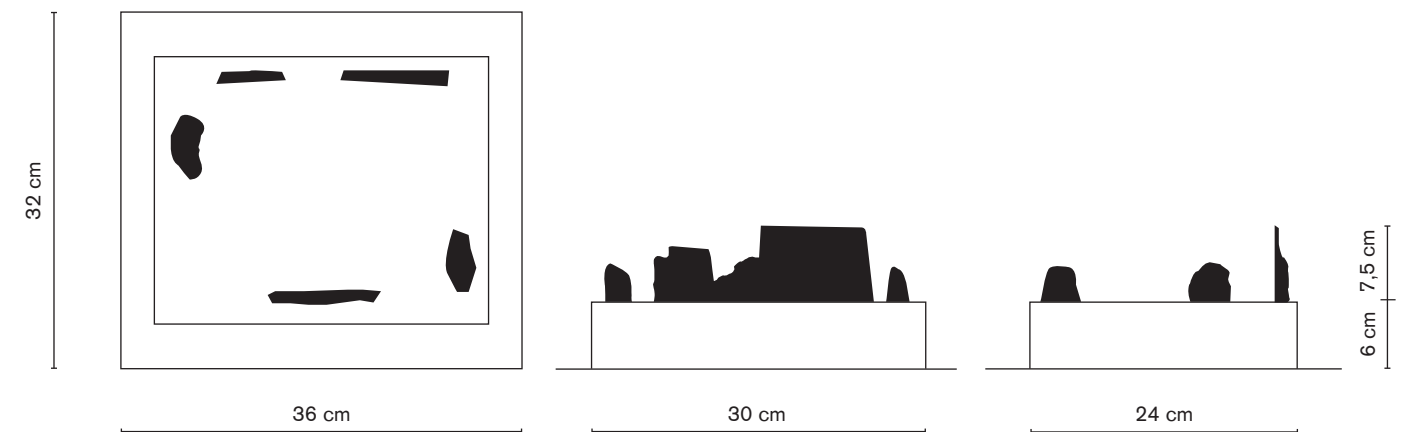



n. 10

Weight: 11,1 kg

Materials: Hand-welded, painted iron  
Fossilized shale; Gold foil;  
Obsidian; Marble

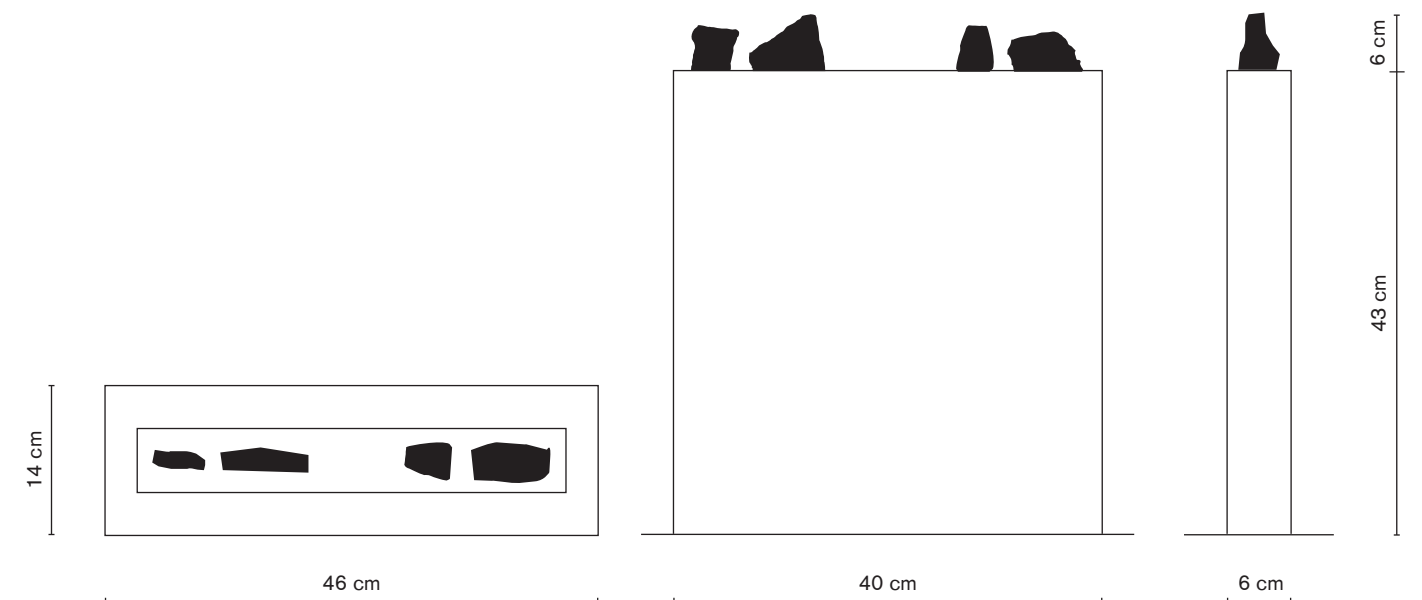





n. 11

Weight: 6,9 kg

Materials: Hand-welded, painted iron;  
Fossilized shale; Gold foil;  
Granite

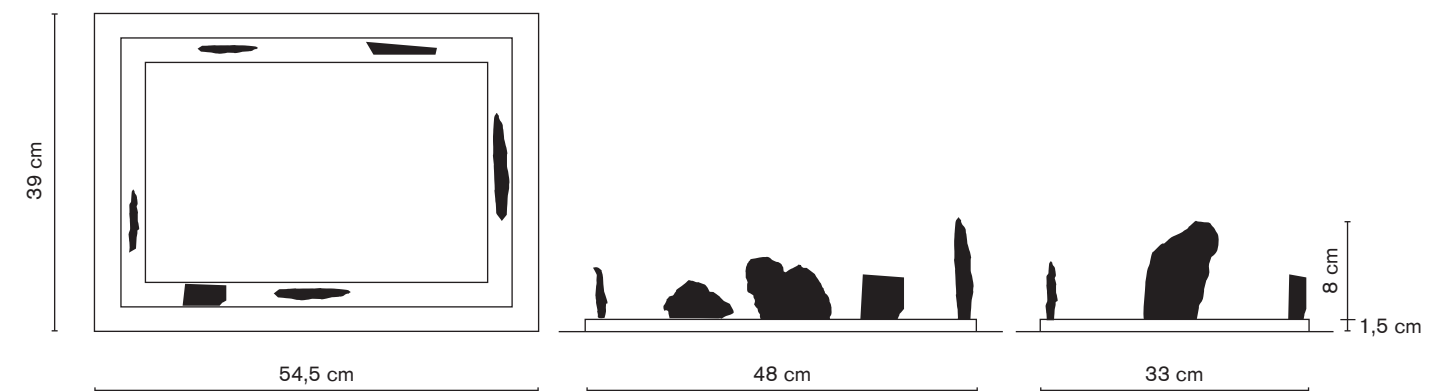





n. 12

Weight: 2 kg

Materials: Hand-welded, painted iron;  
Fossilized shale

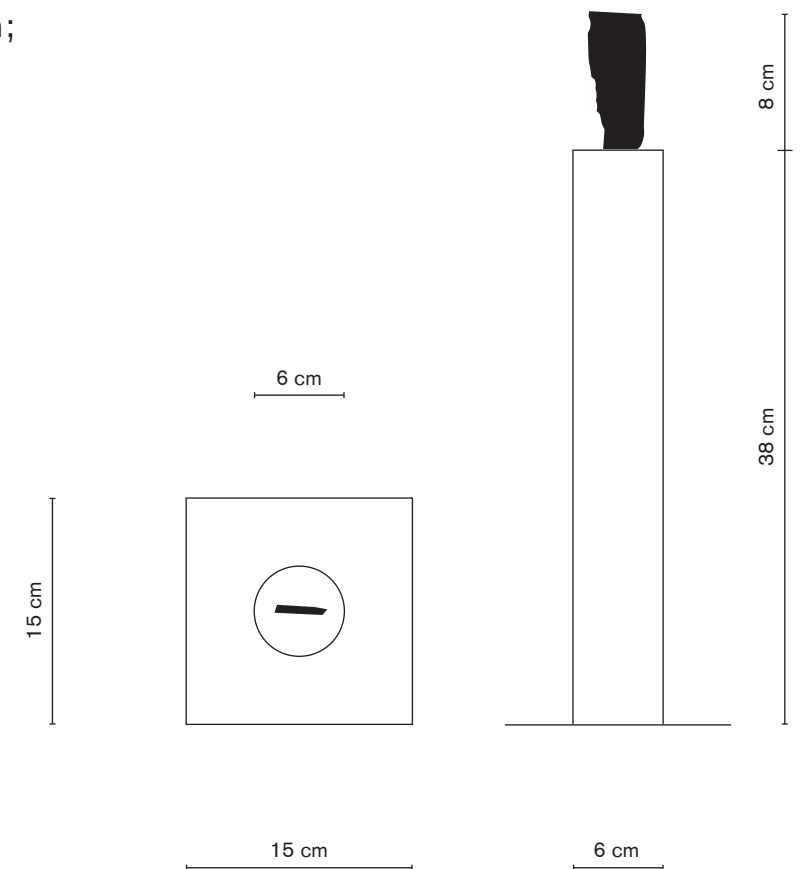



n. 13

Weight: 1,1 kg

Materials: Hand-welded, painted iron;  
Fossilized shale

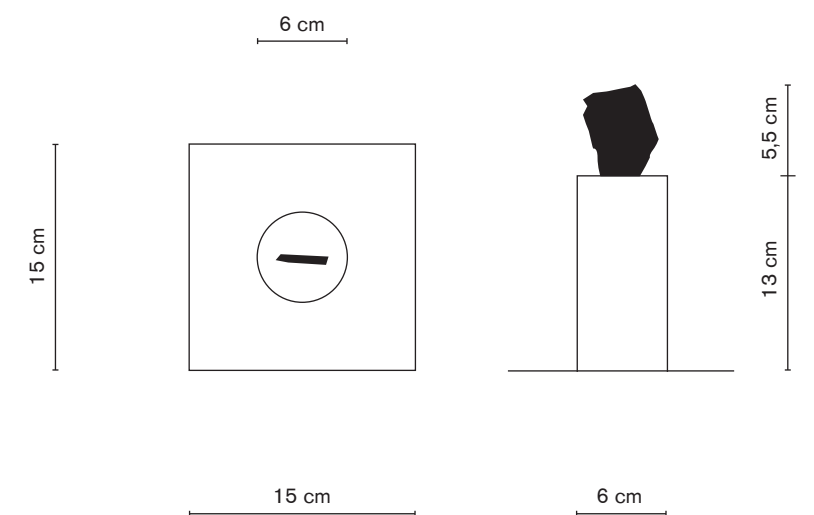



n. 14

Weight: 1,44 kg

Materials: Hand-welded, painted iron;  
Fossilized shale

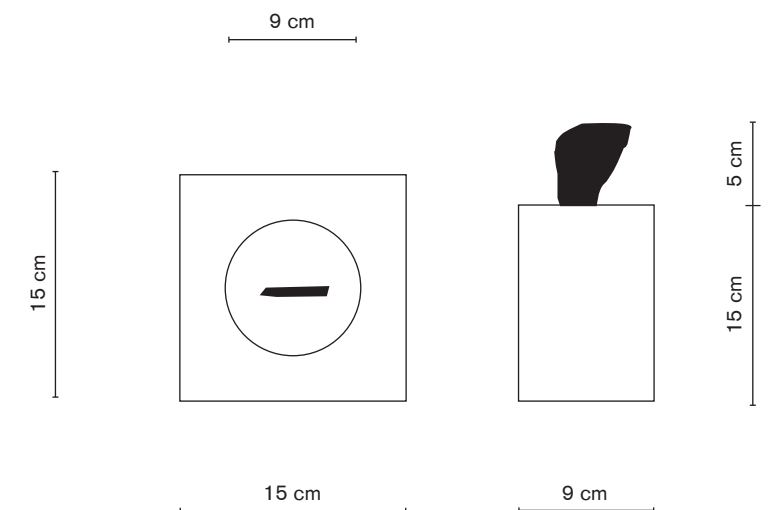





n. 15

Weight: 1,25 kg

Materials: Hand-welded, painted iron;  
Fossilized shale

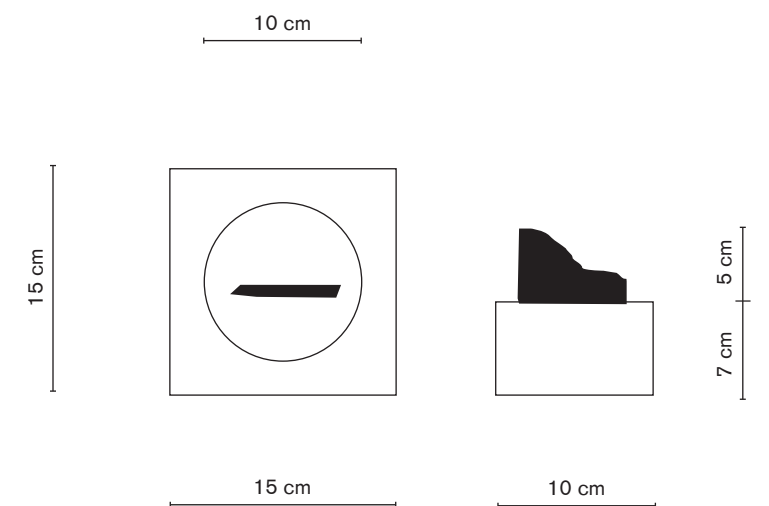

Our work is strictly linked to a specific territory. We concentrate on the difficulties and the blessings of our island because we know that in doing so we are concentrating on the difficulties and the blessings of the whole world over. Our mission is to take the genius of the creatives we work with and cloak it in sardità. With Branzi that action was both natural and extraordinary.

There is a truth to a stone. To its seeming eternalness, to its rigid nature. The stone stands as silent witness through our changing ages, accompanying us with no judgment as to the justice in our choices, in our carving and our selecting, in our stacking, mortaring, our foundations, our bulldozing, our sacred arrangements. But as a witness it does remain, long after the significance of its placement has faded from memory.

We take it for granted that our sacred places would be made of stone; it has become synonymous with sacrality. It has, however, always been abundant - so abundant that to take on special meaning, to mean anything at all, it had to be hauled into specific spaces. One stone had to be declared sacred among many profane.

The dolmen and menhir that dot the Sardinian countryside can fade into their surroundings as though they were shaped by natural forces; the hand of intervention is not immediately clear. However our sense upon encountering them is that precisely these stones in these forgotten places have some ulterior meaning, something to say about the evolution of our architecture, the evolution of our genteel self-distancing from nature, about our constant return.

And how do we transform that inanimate stone that so speaks to us of worlds we only imagine, of lava streams and flooded rivers, of momentous creation that outpaces our comprehension? How can we imbue the stone with more than its own weight, make it weigh more heavily with the message of our hopes? And why do we need them to care, to stand as our witness, to become a representation of our sacred thoughts in their endless silence?

These miniature stones of Branzi's are arranged as if at random upon their metal boxes, the two materials devotedly fastened to each other, and each made more noble by contrast. A stone is the epitome of the superiority of patience - messages delivered through fossils. It is a material that stands as proof of our youth and impermanence, while metal

has been mastered through process, with our hands and our minds, wrought and blasted and forged and shaped.

We have the habit of considering time linear, of dividing the world in inanimate and animate. We have the habit of deciphering our own actions, of assigning them importance or uselessness. We take an object and instill it with meaning. We take a concept and make it material.

These boxes, then, become bearers of preciousness. They take an unknown island and transform its narrative into a presence. They resemble miniatures of sacred places and, in doing so, they speak of the island's fascination with a specific, multitudinous and diversiform material. The metal encloses experience and territory, and the stones, arranged like so many watching menhir, lend their weight.



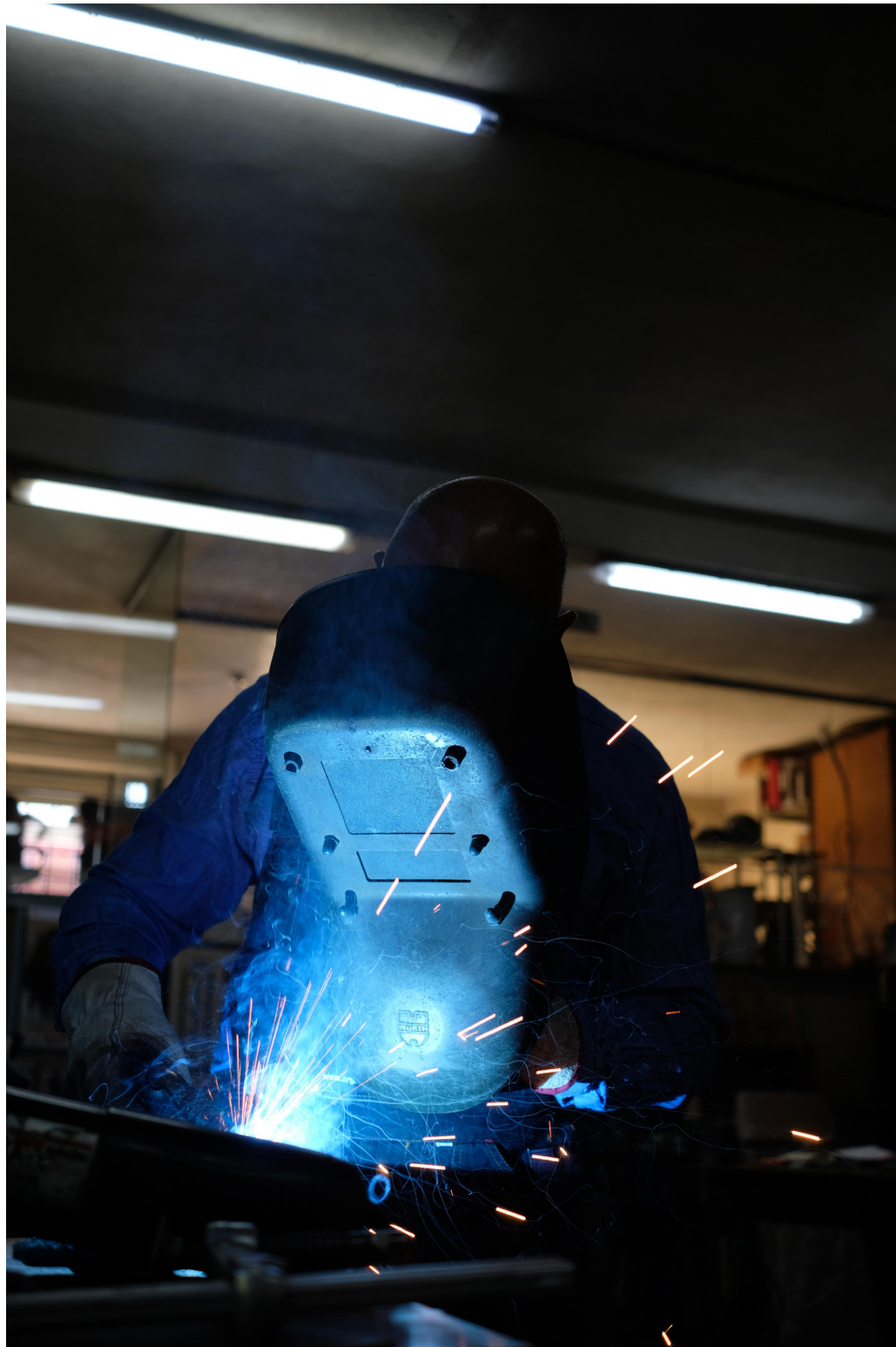

ph. Ivano Atzori

Each sculpture is made of hand-welded iron, assembled in the second generation F.Ili Argiolas workshop.

The fossilized shale is alternately covered in gold leaf or left in its natural state. Other stones were gathered from throughout the Sardinian countryside. Sardinia presents some of the most varied and ancient geological make-up of Western Europe.





Immortale n. 15

Pretziada is a creative practice, based on the island of Sardinia, that promotes the heritage of a territory through words, photography and a collection of design objects made by local artisans.

For pricing and availability:  
[contact@pretziada.com](mailto:contact@pretziada.com)

**PRETZIADA**

[www.pretziada.com](http://www.pretziada.com) / [instagram @pretziada](https://www.instagram.com/pretziada)